

THIS DOCUMENT AND THE DATA DISCLOSED HEREIN AND HEREWITH IS NOT TO BE REPRODUCED USED OR DISCLOSED IN WHOLE OR IN PART TO ANYONE WITHOUT THE WRITTEN AUTHORIZATION OF ENVIROSYSTEMS.

THIS DRAWING HAS BEEN APPROVED AND IS BEING USED BY CUSTOMER AS SHOWN BY THE SIGNATURE OF THE DRAWING OFFICER.

AWM00 - 08/14/09

ITEM	QUA.	P/N	DESCRIPTION
------	------	-----	-------------

NOTES:

- ALL SYSTEMS INCORPORATE REVERSE PULSE-JET CLEANING USING AUTOMATIC SEQUENCE CONTROL, DIAPHRAGM VALVES, AIR PRESSURE ACCUMULATOR TANK & PULSE-JET BLOW PIPE, FACTORY ASSEMBLED. FAN SHIPPED SEPARATELY.
- CONSTRUCTION: 18 GAUGE GALVANIZED STEEL ON STRUCTURAL SQUARE STEEL TUBE FRAME.
- LARGE AREA AIR INLET REDUCES AIR VELOCITIES THROUGH BAFFLES, RESULTS IN LOWER OPERATING PRESSURE DROP AND LESS HP REQUIREMENT.
- FIELD CONNECTION POINTS:
ELECTRICAL: 3 PH, LINE TO STARTER AND STARTER TO MOTOR.
1 PH, 120V, TO PULSE CONTROL SYSTEM.
AIR: 1" NPT FITTING (LOCATED IN BOTTOM LEFT TUBE SHEET).
- COMPRESSED AIR REQUIRED: 90-100 PSIG OF CLEAN, DRY AIR. SYSTEM USES APPROX. 3 CFM
- POWER: 208/230/460 VAC, 3 PHASE, 60 HZ. SEE CHART BELOW FOR FLA REQUIREMENT 120 VAC, 1 PH, 60 HZ. (5.0 A)
- OPTIONS: (SELECT AS REQUIRED)
 - SAFETY MONITORING FILTER PACKAGE DOES NOT INCLUDE DUCTING FROM FAN (CONSULT FACTORY) (SHIPPED LOOSE)
 - SAFETY FILTER, ASHRAE 95%
 - SAFETY FILTER, HEPA
 - 380/575 VAC ELECTRICAL SYSTEMS
 - 50 HZ ELECTRICAL SYSTEMS
 - FAN SILENCERS. (SHIPPED LOOSE)

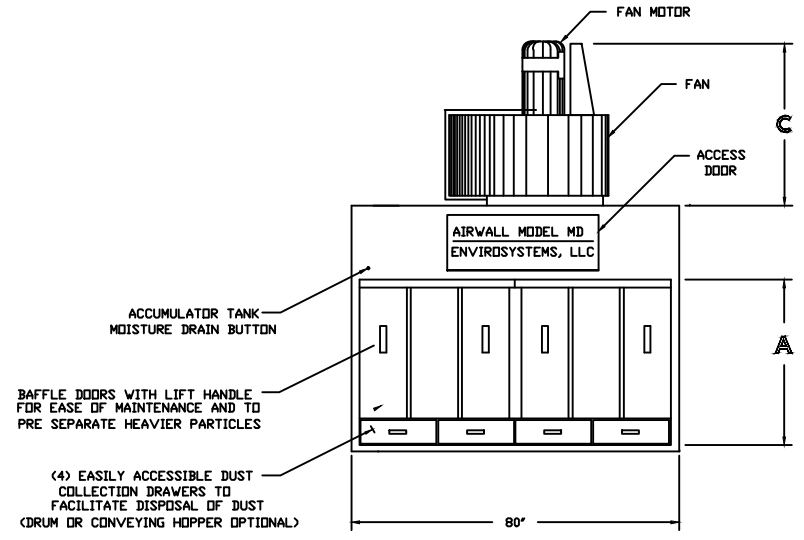
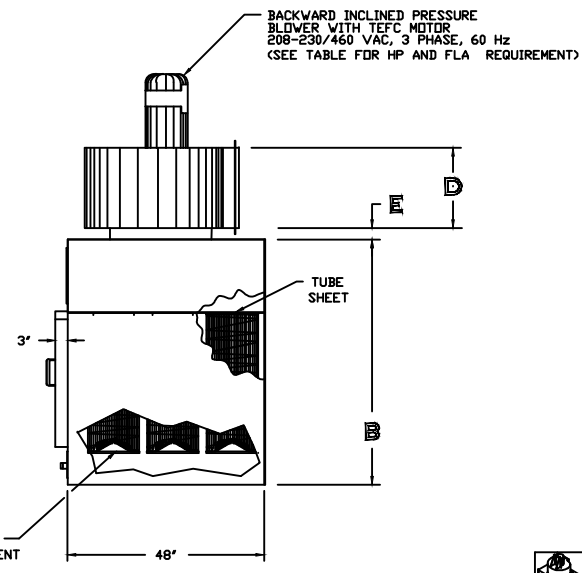
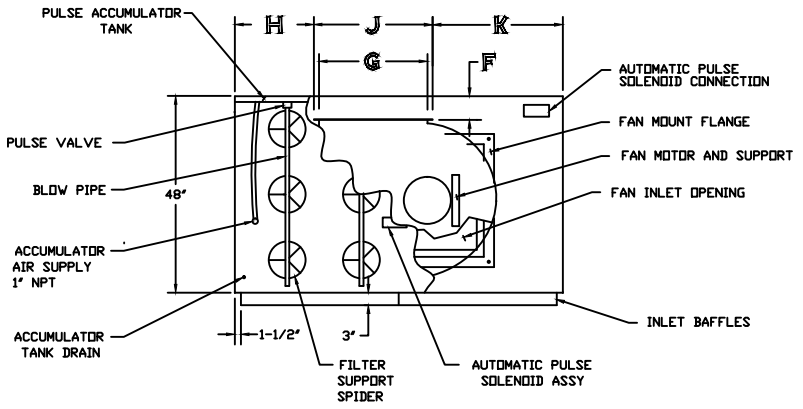

MODEL NO.	TOTAL CFM	CARTRIDGE FILTER ELEMENT			BLOWER	FAN INLET OPENING	A	B	C	D	E	F	G	H	J	K	AIRWALL PART NO.	MOTOR FLA @ 460V	
		QTY REQ'D	TOTAL FLTR AREA (SQ FT)	AIR TO FLTR RATIO														208/230V	460V
AW60MD	6,000	15	3,600	1.67 : 1	5 HP	31X31	40"	60"	32"	14.8"	2"		22.38"		26.38"		1003	17.5/15.2	7.6
AW80MD	8,000	15	3,600	2.22 : 1	7-1/2 HP	34X34	40"	60"	35"	16.63"	2"		24.88"		28.88"		1005	25.3/22.0	11.0
AW100MD	10,000	15	3,600	2.78 : 1	10 HP	34X34	40"	60"	36"	17.25"	2"		27.38"		31.38"		1006	32.2/28.0	14.0

		REVISION HISTORY CHANGE DESCRIPTION 3000 E. President St. Tucson, AZ 85714 800-999-0501	
APPROVALS DRAWN: KEA CHECKED: GO DESIGNED: KEA DATE: 2/10/91 DATE: 2/10/91 DATE: 1/10/91 DATE: 1/10/91		TITLE AIRWALL MODEL MD GENERAL DATA	
DO NOT SCALE DRAWING		FILE LOC. PRODUCTS/RELEASED	